



General information:
Properties
Use as sliding material
Design recommendations

Contents

Page

Properties	3
a) Porosity	3
b) Bulk density	4
c) Chemical resistance	4
d) Temperature resistance	4
e) Strength	4
f) Hardness	4
g) Thermal conductivity	5
h) Coefficient of thermal expansion	5
i) Resistance changes in temperature	5
j) Sliding properties	5
Use as sliding material	8
a) Advice on working conditions	8
b) Choice of materials	8
Design recommendations	9
Introduction	9
General design recommendations	9
Pressed-to-size (p. t. s.) and partially pressed-to-size parts made from pitch-coke bonded carbon and graphite materials (FH grades)	11
Pressed-to-size (p. t. s.) and partially pressed-to-size parts made from synthetic resin bonded carbon materials (FF grades)	15

Properties

Information about the production of carbon and graphite materials is given in our PDF 03.05 “Carbon and graphite, production, material properties”.

The physical values of our standard grades for bearings, sealing elements and other components are summarized in the PDF 30.14 “Characteristics – Standard materials”.

Some of the properties of carbon and graphite with particular regard to use for mechanical applications are shown below.

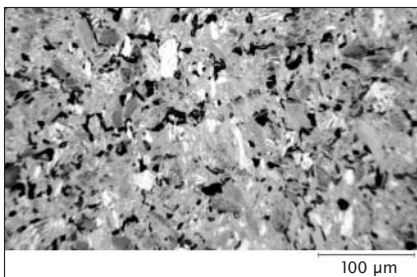

Section of a non-impregnated grade of carbon-graphite. Magnification x 200

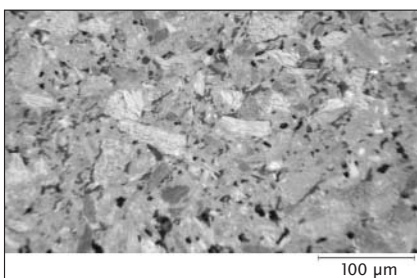

Section of synthetic-resin-impregnated grade of carbon-graphite. Pores filled with synthetic resin. Magnification x 200

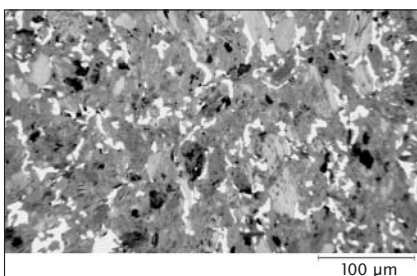

Section of metal-impregnated grade of carbon-graphite. Pores filled with metal. Magnification x 200

a) Porosity

Due to the production method carbon/graphite materials have to be regarded as ceramics.

During the baking process, the bonding agent is reduced thermally to carbon. The volatile constituents of the bonding agent cause a certain porosity of the materials which ranges, according to composition and structure of the basic mix of materials for mechanical applications, between approximately 8 and 25% by volume. This results in permeability to fluids and particularly to gases. For some applications, the pores present in the materials are harmless. On the other hand, carbon materials with higher porosity are generally unsuitable for sealing components, for example seal rings in mechanical seals.

There are several possibilities to reduce or almost eliminate the open porosity of carbon and graphite materials.

1. Single impregnation followed by a thermal decomposition of the impregnating agent to carbon. However for sealing rings multiple cycles may be required.

Advantages: Increases strength and hardness. No influence on chemical resistance.

Disadvantages: Expensive and time consuming process.

2. Single impregnation with synthetic resin which is then cured. However, for sealing rings multiple cycles may be required.

Advantages: Distinct increase in strength, hardness and wear resistance.

Disadvantages: Reduction in temperature resistance and minor restriction to the chemical resistance.

3. Single impregnation with metals: Antimony, lead alloys and copper.

Advantages: Greatest possible increase in strength and hardness together with an improvement to the wear resistance.

Disadvantages: Restrictions to the chemical resistance and, especially with lead alloys, reduction of the temperature resistance.

4. In addition, the pore free resin-bonded carbon materials can be mentioned, their chemical and thermal resistance being defined by the bonding resin.

Advantages: Low cost manufacturing of mass-produced parts by pressing to size of even complicated parts.

b) Bulk density

Because of the pores which are present, it is usual with carbon materials to state the apparent or bulk density. With non-impregnated grades, this varies between 1.5 and 1.8 g/cm³, with metal-impregnated grades between 2.2 and 2.8 g/cm³ and with synthetic resin-impregnated grades it lies around 1.8 g/cm³.

c) Chemical resistance

Because of their excellent chemical resistance, carbon/graphite materials can be classified as corrosion-resistant materials.

For details see our publication 39.12 "Bearing and Seal Technology – chemical resistance".

d) Temperature resistance

Non-impregnated carbon/graphite materials will be subject to oxidation from about 350 °C in the presence of air. With electrographite, however, noticeable oxidation can not be expected until approx. 500 °C.

With special treatment the temperature-resistance of electrographite in an oxidizing atmosphere can be raised to 600 – 650 °C.

In non-oxidizing atmospheres carbon and graphite can be used in temperatures up to those corresponding to the treatment temperature in the production process, i.e. approx. 1000°C or approx. 2500°C respectively.

With the synthetic resin and metal impregnated grades the temperature resistance is limited by the decomposition point or melting point of the impregnating agents used.

Resin impregnated carbon/graphite materials can be used at continuous temperatures of 180 – 260°C dependent on the type of resin used and on its thermal post treatment. Synthetic resin bonded grades can only be used in continuous operation up to a maximum of 180°C.

e) Strength

When working with carbon, as with all ceramic materials, a certain brittleness must be taken into account. Because of this greater brittleness, in comparison with commonly used metallic materials, the strength of carbon/graphite materials cannot be characterised by statements of tensile strength and elongation values. Instead it is generally customary to state the bending and compressive strength and the modules of elasticity as characteristic values.

Since carbon/graphite materials have a low tensile and bending strength but a relatively high compressive strength an appropriate design for the material involved should always be considered.

Unlike metals, its strength does not decrease considerably with raising temperatures but is actually slightly increased.

f) Hardness

In order to permit comparisons with the hardness values of other materials we have listed the Brinell hardness as well as the Rockwell-hardness (HR) in our PDF "Carbon and graphite for mechanical applications – characteristic values". For our regular quality control we do not refer to the Brinell hardness as it is only valid if the surface of the porous material is polished.

In our experience, dynamic hardness measurement methods are less suitable because of the structure of the material.

There are problems in stating Shore hardness values because the resulting values are greatly dependent on the equipment used.

With our carbon materials we therefore determine the hardness values HR 5/40, HR 5/100 and HR 5/150. For these a 5 mm steel ball is pressed into the specimen to be tested with a 98 N initial load and a 294 N, 883 N or 1373 N additional load. After removal of the additional load the resulting depth of penetration is a measure of the hardness HR 5/40, HR 5/100 or HR 5/150 respectively (non dimensional units). It is read off on the B scale of the Rockwell hardness tester.

g) Thermal conductivity

In the following table, the thermal conductivities of carbon/graphite, electrographite and, for comparison, a number of other materials are summarized. As compared with carbon/graphite grades (hard carbons), electrographites are distinguished by a considerably higher thermal conductivity.

h) Coefficient of thermal expansion

A further characteristic which must always be taken into consideration when designing with carbon materials is the low coefficient of thermal expansion when compared to metals.

With a value of 2 to $6 \cdot 10^{-6}/K$, this is only about a quarter of that of steel.

Exceptions to this rule are the synthetic resin bonded grades, the coefficients of thermal expansion of which are of the same order as steel.

i) Resistance to changes in temperature

The resistance to changes in temperature of carbon/graphite and especially of electrographite, defined as the quotient between the products of strength and thermal conductivity on one hand, and of the modulus of elasticity on the other, must be classified as outstanding. Synthetic resin bonded carbons excepted.

j) Sliding properties

Because of its special crystal structure, graphite, whether natural graphite or electrographite, has lubricating properties. Since graphite is always used as a constituent in the production of hard carbons (carbon/graphite grades) for bearings and sealing parts, these grades, as well as the electrographite grades, contain a significant amount of dry lubricant.

Even without additional fluid lubricants, the coefficient of friction between carbon materials and the material of the counterface is therefore comparatively low, provided that the quality of the sliding surfaces is satisfactory.

Because of the wide variation in operating conditions, no generally applicable data on the coefficient of friction can be given.

With dry running on grey cast iron or steel, a coefficient of friction of the order of $\mu = 0.1$ to 0.3 can be expected.

The coefficient of friction is generally considerably reduced by the presence of liquids or vapours, the nature of the liquid or vapours is of lesser importance, so that even in mixed friction conditions a coefficient of friction of $\mu < 0.1$ can be expected.

Material	Thermal conductivity at + 20 °C in W/mK
Electrographite	40 to 130
Carbon/graphite	8 to 17
18/8 chrome-nickel steel	15
Grey cast iron	45 to 60
Copper	395
Bronze SnBz 12	38
Cast chrome steel	19
Sintered ceramic (Al ₂ O ₃)	21
Silicon carbide	80 to 130

The following four graphs give guideline values for the coefficients of friction between carbon/graphite and grey cast iron or steel in dry-running conditions. The first graph, in which the coefficient of friction is plotted against the running-in time, shows that the coefficient of friction decreases with the progress of running-in and the associated progressive smoothing of the sliding surfaces, until a constant value is reached. Far more important certainly, is the fact that the coefficient of friction is a function of sliding speed and specific loading. Graphs 2 and 3 show this relationship for the non-impregnated carbon/graphite grade -FH44Y3-.

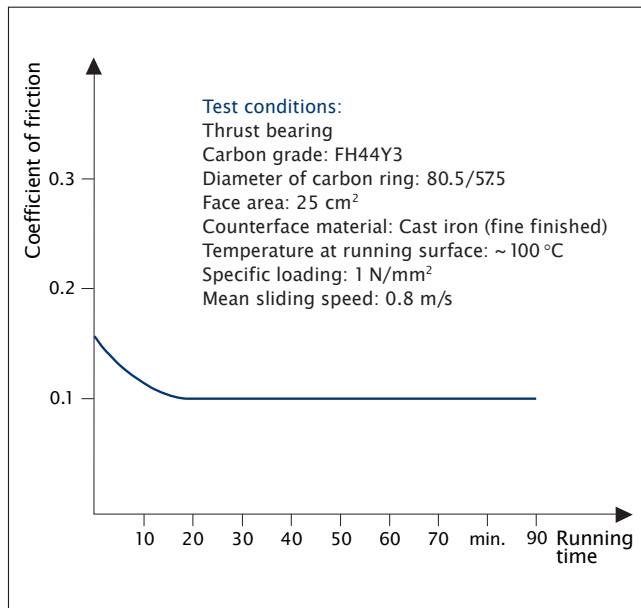

Variation of the coefficient of friction μ during running-in

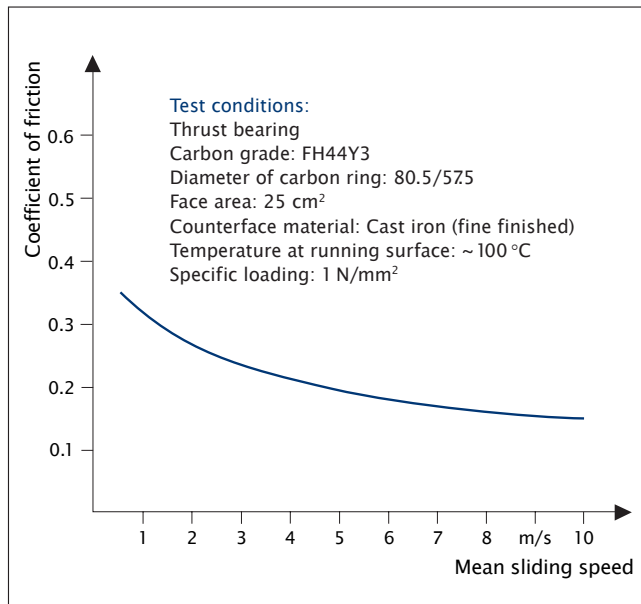

Coefficient of friction μ as a function of the mean sliding speed

Coefficient of friction μ as a function of the specific loading

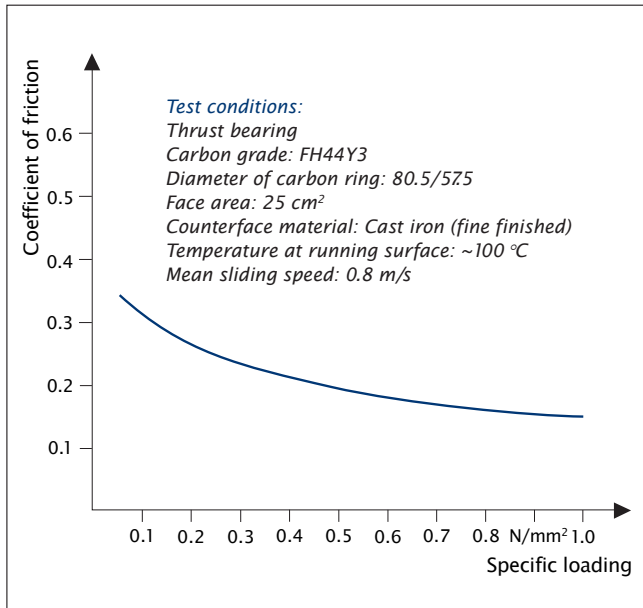

In graph 4*, the relationship of the coefficient of friction on the specific loading at two constant running speeds is shown for the synthetic-resin-impregnated carbon/graphite grade -FH44Z2-. It should be stressed that carbon materials in contrast with some other substances with a low coefficient of friction, also have an excellent wear resistance.

Coefficient of friction μ as a function of the specific loading of the material combination FH44Z2/steel

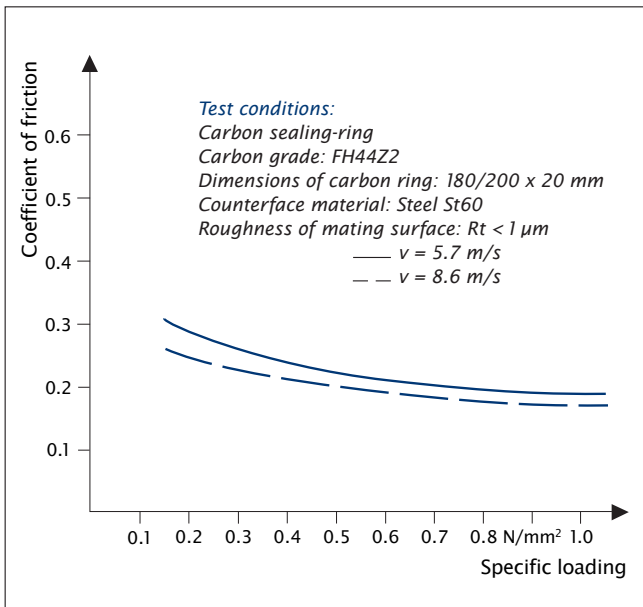

* Taken from: Techn. Hochschule Darmstadt: Thesis by Dipl.-Ing. H. Hartmann "On the temperature variation and the limits of use of dry-running graphite sealing rings".

Use as sliding material

a) Advice on working conditions

The use of carbon/graphite materials is recommended under the following conditions and advantageous compared to other sliding materials :

1. With liquids with unfavourable lubricating capacities e. g. water, aqueous solutions, fuel, liquified gases etc., having no or minimal anti-friction effect with other material combinations.
2. At high or low temperatures exceeding the temperature limits of lubricating oils or greases.
3. With corrosive or radio-active gases or liquids which exclude the use of other sliding materials.
4. In such cases where sliding surfaces may get into contact with oil or grease solvent agents.
5. If a product must not be contaminated by oil or grease.
6. When oils or greases are incompatible with a process.
7. Fields of application where solvents, cleaning or sterilising agents are required.
8. Fields of application where the weight of the component takes priority.

Due to these special capabilities SKT carbon and graphite materials have proved successful under the operating conditions and in the fields of application as described above. Carbon and graphite are chemically resistant against oil, therefore sliding components made from these materials are successfully used in oil pumps and for sealing against oil (including as a barrier liquid).

However, allowing small amounts of grease or oil to come into contact with the sliding surfaces must be avoided because, especially at higher temperatures, a paste can develop which is made up of oil or grease and rubbed-off carbon particles or solid impurities originating from the surroundings can be expected. This paste which toughens on cooling down may lead to mechanical or starting problems.

b) Choice of materials

For special questions and above all for new applications our application engineers are at your disposal.

We gladly offer our services for advice and to provide problem solving proposals, however details regarding the application and the operating conditions must be made available to us.

Design recommendations

Introduction

Since all sliding elements are manufactured by Schunk according to customers drawings and/or specifications, the designer is not limited to standard patterns with regard to design, dimensions and material.

On the other hand, the special properties of carbon/graphite materials, as described in the first paragraph of this publication, must be considered in the design of sliding bearings and sealing elements.

It is therefore useful to contact us at a very early stage of planning a new component in order to avoid designs which, for carbon/graphite materials, are disadvantageous or unproducable.

General design recommendations

In the design of engineering parts in carbon/graphite or graphite materials, attention must be paid to its ceramic nature and associated special properties of this group of materials in comparison with metals.

Because of the lower mechanical strength of carbon materials, in comparison with metals, the wall thickness should, wherever possible, be no less than 3 mm. With circular bodies, the wall thickness should be set at 10 to 20% of the internal diameter, depending on the size of the parts.

As far as possible, the length of the parts should be so selected, that it does not exceed twice the outside diameter. If necessary a division into two or three pieces must be allowed. Long, narrow bores should be avoided, because of the difficulties in maintaining tolerances.

Because of the danger of breakage and also for reasons of cost, it is advisable to avoid large changes in cross-sections. As an alternative, the part can be sub-divided into a number of parts, each with a uniform wall thickness.

If parts in carbon/graphite or graphite materials have to be secured against rotation, screws and cotter pins cannot be used because of notch effects and the danger of breakage. The protection against rotation must be achieved with a plain pin, which exerts no pressure on the carbon material and acts on an unloaded part of the carbon body.

Sharp edges should be broken and sharp transitions avoided.

Carbon parts need to be supported, when pressed or shrunk into metal bushes or directly into housings, as far as possible over their whole length. If they are installed self supporting, correspondingly large wall thicknesses should be provided.

With machined one-piece carbon parts, an internal tolerance of IT7 and an external tolerance of IT6 can be achieved. With multi-part bodies, tolerances selected over several rough tolerance ranges are generally quite adequate.

The above mentioned tightest possible tolerances for one piece, machined carbon parts are often necessary e.g. with radial carbon bearings. At times, however, considerably coarser tolerances are sufficient for machine parts in carbon/ graphite materials or a close tolerance is only necessary for one dimension.

For carbon parts, which are required in large numbers, pressing to a finished or substantially finished state can be done.

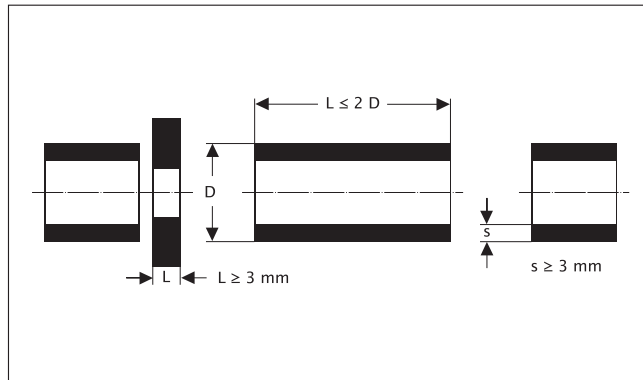

Sub-divided into several plain parts

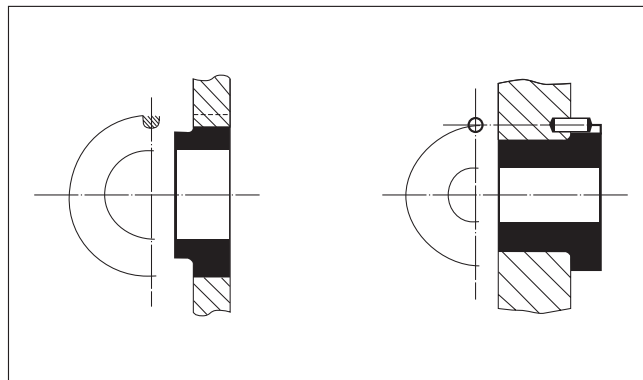

Protection against rotation with plain pin in the unloaded part of a carbon body

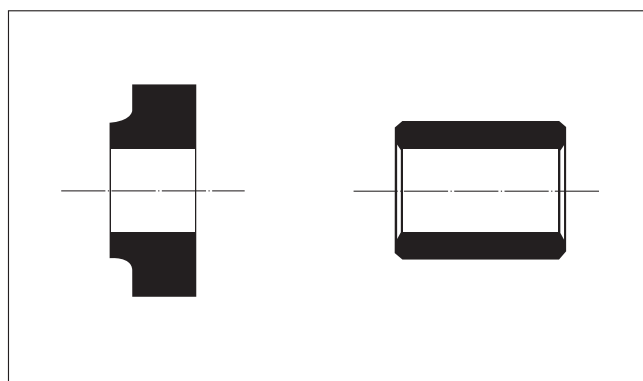

Transitions radiused, edges broken

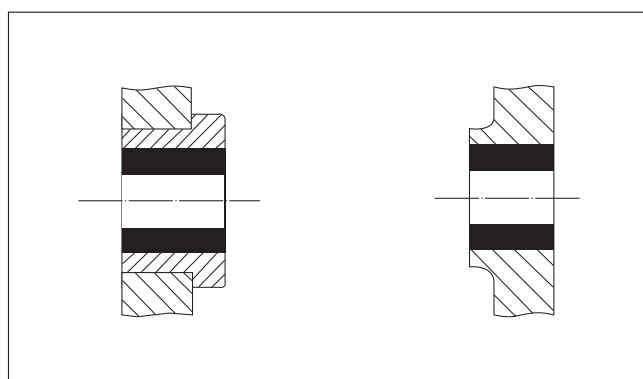

Carbon parts shrunk or pressed into metal bush or directly into housing

Pressed-to-size (p. t. s.) and partially pressed-to-size parts made from pitch-coke bonded carbon and graphite materials (FH grades)

Taking into account the stoppable tolerances, carbon parts can also be produced pressed-to-size or partially pressed-to-size, so that only partial further machining has to be carried out, for example:

- with thin-walled sections which cannot be pressed
- with undercut steps in the axial direction
- or the machining of running surfaces on carbon sealing-rings.

With cylindrical carbon bearings outer and/or inner diameters often have to be machined.

The p.t.s.-pressing technique, the compression of the prepared carbon mixtures to form the desired moulded parts directly, has long been in use at Schunk, for instance

for carbon brushes and contacts for electrical machines when large quantities are required.

In order to keep the shrinkage which occurs during the furnacing within the smallest possible tolerances, the p.t.s. operation is followed by a special furnacing process. During shrinkage, the original shape of the moulded carbon part is maintained. Throughout the manufacturing process QA measures are applied, e.g. SPC.

In the last 40 years, this technique has been continuously improved, in order to be able to produce parts of more complicated design, for example carbon sealing-rings and carbon bearings, in a ready-pressed form.

Some examples below:

- Sealing rings for automobile water cooling pumps, water pumps, swimming pool pumps, dish-washer lye pumps
- Thrust bearing segments
- Bearings for magnetic driven pumps, injection pumps
- Bearings for circulating heating pumps
- Control valves



Sealing rings for automobile water cooling pumps, water pumps, swimming pool pumps, dish-washer lye pumps



*Bearings for
magnetic driven
pumps,
injection pumps*

Large production quantities of at least 5,000 pieces are a prerequisite for the application of this production method. The determination of the minimum quantities for which p.t.s. can still be practicable in each individual case must always be based on a cost comparison between machining and ready-

pressing, taking into account the sometimes high costs for special dies. For the application of this mass production method, various factors involved in the design of the parts must be taken into account and these will be dealt with in rather more detail in the following sections.

Dimensioning

The minimum wall thickness of a press-formed carbon part should be ≥ 1.5 mm. The maximum height should not exceed 30 mm, taking account of the ratio of the smallest wall thickness to the pressed thickness of 1 : 2.5. This applies correspondingly for the height of steps in profiled parts. If the maximum diameter exceeds 50 mm, an individual decision must be taken in each case on the possibility of production by the p.t.s.-method. The smallest carbon bearing so far produced economically in large quantities has dimensions of 1.8/0.5 mm diameter \times 1.0 mm.

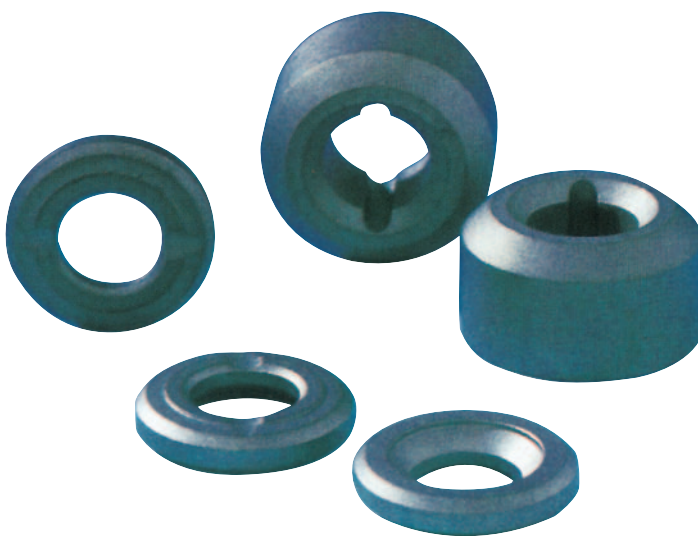

*Bearings for
circulating heating
pumps*

Tolerances

The dimensional tolerances which can be maintained with press formed parts after the furnacing process are dependent on the design and size of the part. In relation to the diameters, 1.2% can be indicated as reference values for parts being manufactured under process control. For dimensions in the direction of pressing, for example for ring thickness, a tolerance of ± 0.10 up to ± 0.25 mm will generally be needed. Definite tolerances should be fixed after experimental manufacturing with statistical evaluation.

Design forms

As well as tolerances and the smallest and largest possible dimensions, the shape must also be adapted to the relevant press technology. In relation to this, the expenditure for the production of the press tool should also be considered.

The most important points which have to be observed when designing the shape of p.t.s. carbon parts are listed below.

The press tools, with a vertical press axis, must be designed so that uniform compression is obtained over the whole cross-section and that satisfactory ejection is also ensured.

To improve this, tapers up to 1° should be allowed, as far as possible, both for the largest outside diameter and the smallest inside diameter. Broken edges and chamfers should be applied at an angle of $\leq 45^\circ$. In general broken edges should be provided on all edges of the pressed pieces unless it has openings.

With p.t.s. parts, steps, staggered in relation to one another, on the outer circumference and in the bore should be avoided as far as possible, i.e. external steps require straight-through bores and vice versa.



Control valves

If, as well as an external step, an internal step is absolutely necessary, the internal step should not significantly exceed a depth of 1 mm. It should be reiterated that experiments to determine whether production is possible are worthwhile in special cases.

If vertical grooves are necessary, these should be arranged continuously (i.e. straight-through) and all transitions should be radii.

Radii are useful with transition ≥ 2 mm. Steps in the radial direction are to be ≥ 1 mm.

The design sketches shown are intended for guidance and illustrate the statements made in the text.

All the information given so far with regard to the p.t.s.-technique applies to our p.t.s.-

carbon/graphite grades such as

- FH421-,
- FH421A-,
- FH421B-,
- FH421Z-,
- FH441Z-,
- FH531B-,
- FH821A-,
- FH821Z-,
- FH841Z-.

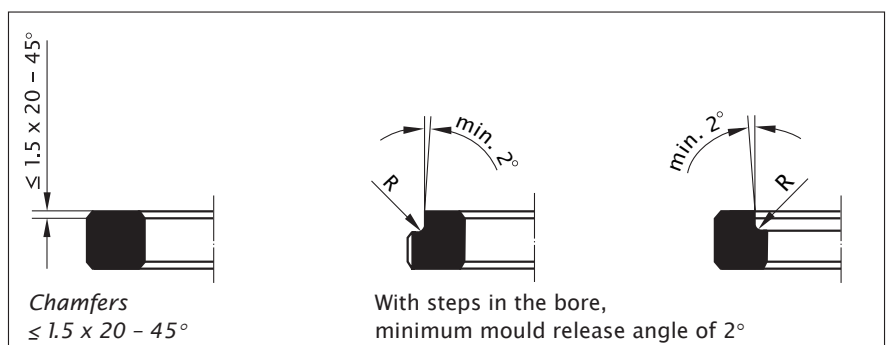
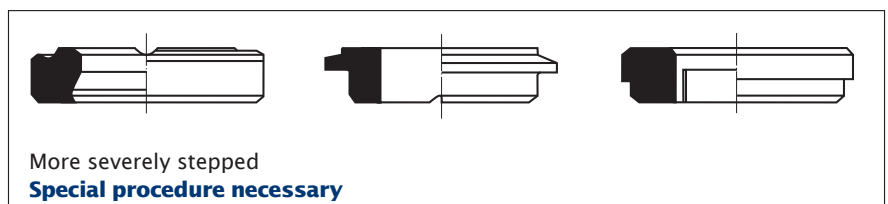
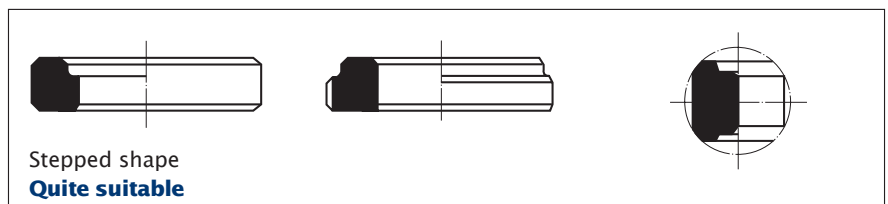

Synthetic resin bonded carbon materials

Pressed-to-size (p. t. s.) and partially pressed-to-size parts made from synthetic resin bonded carbon materials (FF grades)

These materials consist of carbon and/or graphite filled phenolic resin. With the different grades such as -FF501-, -FF521-, -FH541- and -FF601- the compositions and the contents of the fillers are varied in order to comply with the various requirements.

Fields of application are bearings, sealing rings and pump components for use in the automobile industry, in machine and apparatus production and control equipment.



Pump wheel for fuel feed pump in automobiles

Some examples are as follows:

- Bearings for magnetic driven pumps
- Sealing rings for domestic water pumps, oil-burner feed pumps, pumps for washing machines and automobile cooling water pumps
- Complete pumps for central locking and orthopaedic seat adjusting systems for automobiles
- Control valves for pneumatic control units
- Pump wheels for fuel feed pumps in automobiles

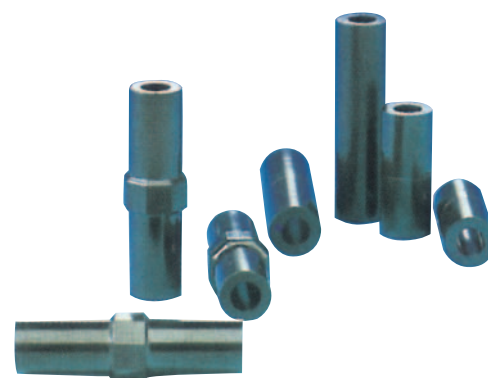

Bearings for magnetic driven pumps

The physical properties of these phenolic resin bonded grades are indicated in our PDF 30.14.

We would like to draw special attention to the temperature resistance of up to 180 °C for the standard grades and the coefficient of thermal expansion being similar to that of steel. With a special thermal treatment the temperature resistance can be increased up to 250 °C. By injection moulding of these materials it is therefore possible to bring formed parts directly onto steel shafts, thus ensuring an optimal connection with a component. Schunk Kohlenstofftechnik has much experience in fully automated production of such parts including the corresponding loading and removal stations.

Sealing rings for domestic water pumps, oil-burner feed pumps, for pumps for washing machines and automobile cooling water pumps



Complete pump for central locking system

These resin bonded materials can be processed by injection moulding and extruding. In particular, injection moulding of these materials allows flexible designing of components and significantly more complicated shapes compared to parts made from pitch-coke bonded carbon/graphite materials (FF grades).

On the other hand, the high costs of the necessary thermal pressing in this case must be considered. Therefore a minimum production lot of 25,000 pieces is required for parts made from resin bonded materials.

Dimensioning

The minimum wall thickness with these materials is primarily defined by the tool manufacture and should not be below 0.5 mm. The maximum wall thickness should not exceed 10 mm due to the fact that the curing of these duroplastic materials in the hot die would no longer allow cost effective production.

Tolerances

After the moulding process in the hot dies the components are only after-cured or stoved in hot cabinets. This heat treatment results in minor dimensional deviations so that for dimensions produced by the tool a tolerance of IT9/IT10 can be indicated as a reference value. For dimensions related to the parting plane of the tool, a tolerance of minimum 0.10 mm can be maintained.

Definite tolerances should be fixed after experimental manufacturing with statistical evaluation.

In order to comply with tolerances which are decisive for the function of a part, process control procedures are used for quality assurance.

Design forms

For the production of resin-bonded components with axial presses in heated dies most of the recommendations for the pressing to-size of pitch bonded carbon/graphite materials (FH grades) can be applied.

This is not the case with injection and transfer moulding, where the moulding compound is injected in an almost liquid phase into a closed hot die. As a result the densification will be homogenous over the entire cross-section of a component. Therefore off-set steps on the outer diameter and the bore can be realised. Furthermore, even if a component has both outer and inner steps this will not pose a problem. With a special tool even undercuts can be realised. Special attention has to be paid to the choice of an appropriate location of the gate mark, since it will influence the properties of the finished part.



Control valves for pneumatic control units

Schunk Kohlenstofftechnik GmbH

Rodheimer Strasse 59
35452 Heuchelheim
Germany

Phone: +49 (0) 641 608-0
Fax: +49 (0) 641 608 1747

sse@schunk-group.com
www.schunk-tribo.com